



EUROPEAN COMMISSION
DIRECTORATE-GENERAL JRC
JOINT RESEARCH CENTRE
Institute for Prospective Technological Studies (IPTS)
Competitiveness and Sustainability Unit
European IPPC Bureau

Sevilla, 03 September 2008
J02-CAS/(2008)D/22147

KICK-OFF MEETING
FOR THE REVIEW OF THE
REFERENCE DOCUMENT ON BEST AVAILABLE TECHNIQUES
IN COMMON WASTE WATER AND WASTE GAS
TREATMENT / MANAGEMENT SYSTEMS IN THE CHEMICAL
SECTOR

SEVILLA, 16 – 18 June 2008

DRAFT MEETING REPORT

INTRODUCTION

The Technical Working Group (TWG) on the review of the Reference Document on Best Available Techniques (BAT) in Common Waste Water and Waste Gas Treatment/Management Systems in the Chemical Sector (the CWW BREF), held its first plenary meeting at the Institute for Prospective Technological Studies (IPTS) of the European Commission in Seville, Spain on 16 – 18 June 2008. This record represents a summary of the results of this first plenary meeting.

Technical Working Groups (TWGs) are set up according to the work programme ratified by the Information Exchange Forum (IEF) to facilitate the exchange of information on best available techniques, associated monitoring and developments in them under Article 17(2) of Council Directive 2008/1/EC concerning Integrated Pollution Prevention and Control (IPPC).

The existing CWW BREF (available on the European IPPC Bureau website at <http://eippcb.jrc.es>) was started in 1999, finalised in 2001 and formally adopted by the European Commission in 2003. The CWW BREF serves as information and guidance for regulators within the procedure of issuing permits to chemical installations. The CWW BREF is also used by other stakeholders such as the industry concerned in preparing applications for operating permits.

This first plenary meeting, also called kick-off meeting, officially started the work on the review of the CWW BREF document based on an exchange of information between the members of the Technical Working Group set up for the purpose.

Mr Harald Schoenberger, Head of the European IPPC Bureau, chaired the meeting and Mr Serge Roudier led the technical discussions.

The meeting was attended by 44 participants:

- 26 representing 14 Member States: Austria (AT), Belgium (BE), Bulgaria (BG), the Czech Republic (CZ), Denmark (DK), France (FR), Germany (DE), Ireland (IE), Italy (IT), the Netherlands (NL), Portugal (PT), Spain (ES), Sweden (SE), and the United Kingdom (UK)
- 10 representing the chemical industry under the umbrella of CEFIC
- 3 representing other interested industrial companies (Air Liquide, John Zink Keu GmbH, Technip)
- 1 representing the European Environmental Bureau
- 4 staff from the European Commission services (DG Environment and the Joint Research Centre).

The agenda of the meeting involved presentations and discussions on the exchange of information on best available techniques (as stipulated in Directive 2008/1/EC), the Commission's proposal to review the IPPC Directive, the definition of the scope of the work to review the CWW BREF and the outline of the CWW BREF. These discussions were covered during the first one and a half days of the meeting. The final half day covered the information exchange tools (i.e. BATIS) as well as the conclusions of the meeting.

In order to facilitate the meeting, a background paper highlighting the items proposed for discussion at the meeting was prepared by the European IPPC Bureau and sent to the TWG members in advance of the meeting (background paper sent on 16 May 2008).

MEETING AND STRUCTURE OF THIS MEETING REPORT

The discussions at the meeting were structured according to the 25 items presented in the background paper. The items had been derived from about 270 wishes sent by the TWG. A "wish" in this context stands for suggestions/comments provided by the members of the TWG to modify the existing CWW BREF.

Each item was discussed in the same way at the meeting: Mr Roudier gave a short presentation summarising the wishes expressed, provided a proposal for the change in the BREF to satisfy these wishes and introduced a final proposal for the tasks that TWG members need to carry out in order to fulfil the wishes. The TWG members then had the opportunity to discuss each item to confirm that the wishes had been interpreted correctly and that the European IPPC Bureau had correctly identified the tasks that need to be carried out. The participants ultimately reached conclusions on each discussion item.

The rest of this meeting report is structured in the same way and relates to the items discussed during the meeting. In this report, each item contains a brief summary of the discussion, if necessary, and the conclusions reached during the meeting. In particular, and for each item, much information has been identified and will be collected so that it can be shared by the whole TWG in order to review the CWW BREF.

TABLE OF CONTENTS

1	GENERAL	4
1.1	Scope of the CWW BREF	4
1.2	Interface between the CWW BREF and the vertical chemical BREFs	7
1.3	Consistency with the whole series of BREFs	8
1.4	Structure of the CWW BREF	8
1.5	Glossary of terms and abbreviations	9
2	WASTE WATER AND WASTE GAS TREATMENT/MANAGEMENT SYSTEMS	10
2.1	Environmental management system (EMS)	10
2.2	Management of a chemical site	10
2.3	Fugitive/diffuse emissions	11
2.4	Missing techniques	11
3	WASTE WATER	12
3.1	Whole effluent assessment (WEA)	12
3.2	Missing information or new developments in techniques	12
4	WASTE GAS	14
4.1	Wet scrubbers for gas removal and sorbent injection as flue-gas desulphurisation techniques	14
4.2	Control of particulate matter emissions	14
4.3	Miscellaneous	15
5	OTHER ISSUES	16
5.1	Combination of techniques	16
5.2	Water savings and concentrations of pollutants	16
5.3	Energy consumption and energy efficiency	16
5.4	Monitoring of emissions	17
5.5	Odour	17
5.6	Waste	17
6	DATA COLLECTION	19
6.1	General principles for providing information for the review of the BREF	19
6.2	Collecting data on techniques to consider in the determination of BAT	19
6.3	Collecting data on central waste water treatment plants (WWTPs)	20
7	SPLIT VIEWS	20
8	EMERGING TECHNIQUES	21
9	PROCESS TO REVIEW THE CWW BREF	22
10	INFORMATION EXCHANGE	22
11	ANNEX I: STANDARD STRUCTURE FOR DESCRIBING THE 'TECHNIQUES TO CONSIDER IN THE DETERMINATION OF BAT'	24
11.1	Type of information needed to fill the sections dealing with 'Techniques to consider in the determination of BAT' and to derive useful BAT conclusions	25
12	ANNEX II: TEMPLATE FOR THE PROVISION OF INFORMATION ON CENTRAL WASTE WATER TREATMENT PLANTS (WWTP)	27

1 GENERAL

1.1 Scope of the CWW BREF

Because of the complexity of the European chemical industry sector, eight BREFs have been elaborated to cover the entire sector and the CWW BREF the only one of this series of chemical BREFs which covers horizontal aspects of waste water and waste gas treatment.

The other seven chemical BREFs (called 'vertical' BREFs because they only cover a part of the whole chemical sector) are:

- Chlor-Alkali (CAK) BREF
- Large Volume Inorganic Chemicals – Ammonia, Acids and Fertilisers (LVIC-AAF) BREF
- Large Volume Inorganic Chemicals – Solids and Others (LVIC-S) BREF
- Speciality Inorganic Chemicals (SIC) BREF
- Large Volume Organic Chemicals (LVOC) BREF
- Organic Fine Chemicals (OFC) BREF
- Polymers (POL) BREF.

The CWW BREF was one of the first of the eight chemical BREFs to have been elaborated. Its scope covers the whole chemical industry sector. Because of this, and due to its focus on 'common' abatement systems, it has been widely used in the development of, and is referenced in, a number of other chemical BREFs. The CWW BREF is also referenced in a number of non-chemical BREF documents.

Conclusions reached by the TWG for the revised CWW BREF:

- the production of petrochemicals (LVOC) is included; refineries are not
- combined treatments of waste water from refineries and chemical installations (LVOC) is within the scope of CWW if the contribution of the LVOC effluents to the combined treatments is relevant (no fixed criteria)
- combined treatments in municipal waste water treatment plants is within the scope of CWW when the discharge of waste water from chemical installations is relevant (no fixed criteria)
- what is specific to chemical processes/substances is under the scope of vertical BREFs and will not be covered by CWW
- general aspects of pretreatment/abatement techniques (including consumption and emissions levels) are under the scope of CWW; specific aspects, in particular production and process-integrated measures, should be left to the vertical BREFs.

The main task of the TWG will therefore be to submit information on central waste water/waste gas treatment (related to Subject Group 6 on data collection).

Figure 1 below shows how the scope of the CWW BREF will be extended to cover the environmental management of a complex chemical site/park in particular the central treatment of various water effluents. The grey dotted parts of the figure show what will remain under the vertical chemical BREFs. The plain dark parts will be covered in the CWW BREF.

Information identified or promised to be delivered by the TWG for the revised CWW BREF:

- Sweden will look for relevant information on this item
- Industry (CEFIC) will provide data (an update of the information in the existing BREF)
- France will provide information regarding complex chemical sites.

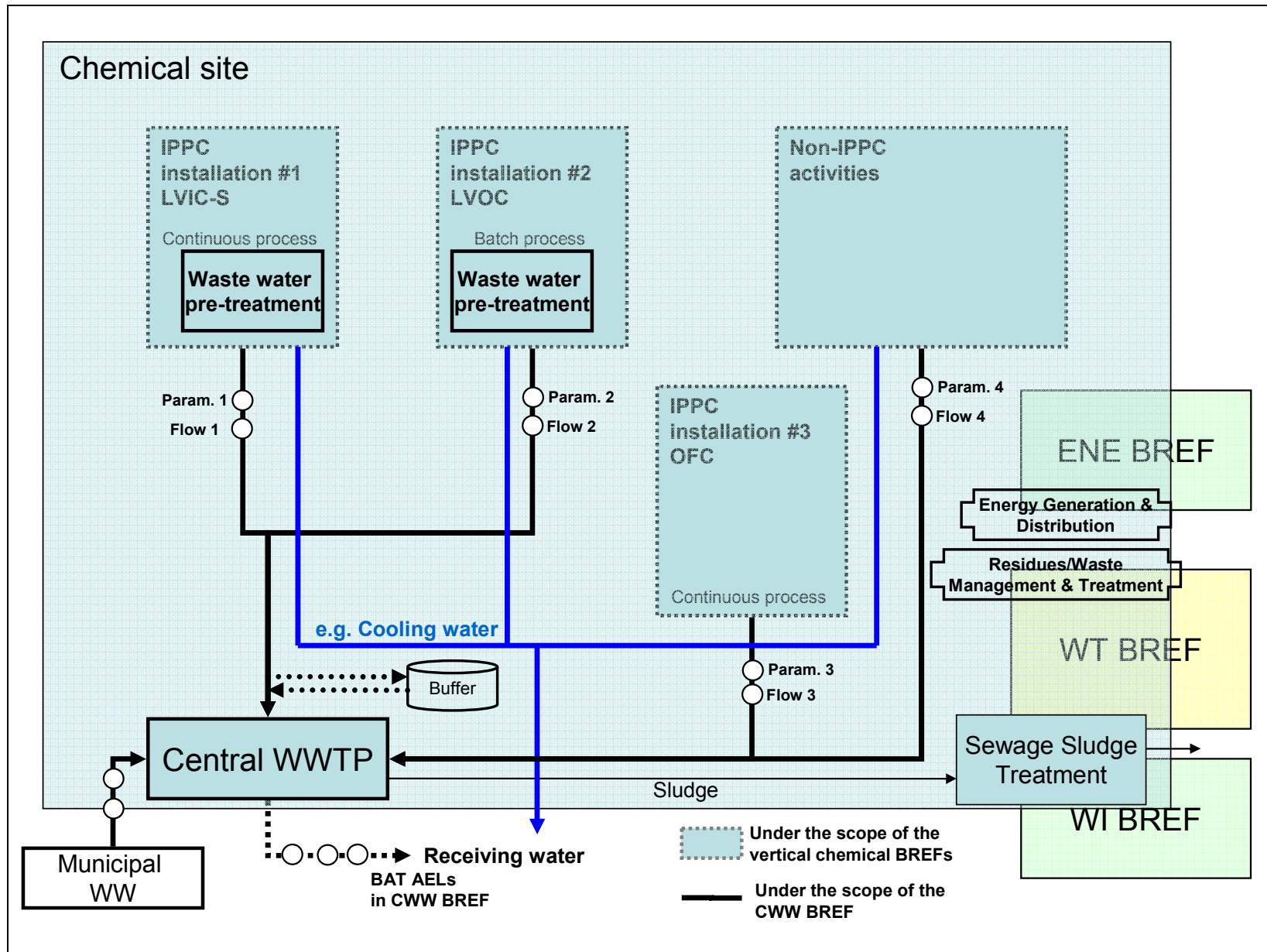

Figure 1: Environmental management of a chemical site, in particular the central treatment of water effluents

1.2 Interface between the CWW BREF and the vertical chemical BREFs

The IEF recognised that a complete coverage of the whole chemical sector is not possible due to the high number of chemical substances produced. The current series of vertical chemical BREFs specifically addresses the production of less than 100 substances or groups of substances. This is the reason why the CWW BREF is an important BREF as its scope covers substances or groups of substances which are not covered specifically in the vertical chemical BREFs. The IEF decided that the TWGs to be set up to review each vertical chemical BREF will assess the generic conclusions in the CWW BREF and decide if they should be made more specific to the vertical chemical BREF.

The most recent horizontal BREF, i.e. the Energy Efficiency (ENE) BREF, has described the interface between the ENE BREF and other horizontal and vertical BREFs, guiding the user in situations when more than one BREF applies.

Conclusions reached by the TWG for the revised CWW BREF:

- it is necessary to clarify in the CWW BREF the borderlines between CWW and the vertical chemical BREFs
- a draft text will be proposed to the TWG by the European IPPC Bureau for the purpose. This text will take into account the precedent set by the ENE BREF as well as proposals in the paper on the comparative analysis of the first series of chemical BREFs
- both the CWW and vertical chemical BREFs should be taken into account when setting permit conditions for chemical installations. The use of the CWW BREF is expected to be of value in particular in the case of complex chemical sites and when waste waters/gases from various chemical (and eventually non-chemical) installations are treated in common/central treatment plants
- aspects generic to the whole chemical industry sector will be included or developed in the CWW BREF and, when appropriate, cross-referenced or even removed from the sector-specific (i.e. vertical) chemical BREFs, e.g.:
 - collection, use and treatment of rainwater
 - energy efficiency measures respective to waste water treatment and waste gas treatment operations
 - safety and security aspects respective to waste water and waste gas treatment operations
 - decommissioning of chemical installations.

The main task of the TWG will therefore be to identify information that can be transferred from the vertical chemical BREFs to the CWW BREF (e.g. rainwater collection and treatment).

To clarify the borderlines between CWW and the vertical chemical BREFs, the European IPPC Bureau will propose a draft text inspired by the ENE BREF and the Comparative analysis of the first series of chemical BREF with a view to be included in the revised CWW BREF.

Information identified or promised to be delivered by the TWG for the revised CWW BREF:

The vertical chemical BREFs can supply information regarding generic aspects such as the ones mentioned above. However, there is also a need to update and complete the information in the CWW BREF via the provision of data by the TWG (see also Subject Group 6 on data collection).

1.3 Consistency with the whole series of BREFs

This item relates to Item 1.4 on the structure of the CWW BREF.

Conclusions reached by the TWG for the revised CWW BREF:

- include current standard texts prescribed by IEF
- improve the cross-references, within CWW (e.g. in the BAT part of the CWW BREF) and from CWW to other BREFs
- describe ‘Techniques to consider in the determination of BAT’ according to the current standards (i.e. BREF Outline and Guide):
 1. Description
 2. Achieved environmental benefits
 3. Cross-media effects
 4. Operational data
 5. Applicability
 6. Economics
 7. Driving force for implementation
 8. Example plants
 9. Reference literature

The standard structure for describing ‘Techniques to consider in the determination of BAT’ can be found in ANNEX I (see Section 11 below).

The TWG is therefore asked to provide (for all the techniques mentioned in Chapters 2 and 3 of the existing CWW BREF) the missing information, in particular under the headings *Driving force for implementation*, *Example plants* and *References to literature*.

Information identified or promised to be delivered by the TWG:

The vertical chemical BREFs can supply information regarding this item. However, there is also a need to update and complete the information in the CWW BREF via the provision of data by the TWG (see also Subject Group 6 on data collection).

1.4 Structure of the CWW BREF

This item relates to Item 1.3 on the consistency with the whole series of chemical BREF.

Conclusions reached by the TWG for the revised CWW BREF:

- the CWW BREF does not need to strictly meet the general structure set in the BREF Outline and Guide
- the revised structure proposed by the European IPPC Bureau at the meeting was accepted and will be implemented with all the refinements that the TWG will decide in the course of the review process. The proposed structure is shown in Figure 2
- for each individual treatment technique, as well as for the common treatment techniques, consumption and emission levels will be given, as part of the nine headings structure indicated in Item 1.3.

Structure of the current CWW BREF	Structure of the revised CWW BREF
Preface	Preface Large, integrated chemical sites
Scope	Scope
Chapter 1: General description	Chapter 1: General information
Chapter 2: Waste Water/Waste Gas Management	Chapter 2: Techniques to consider in the determination of BAT
Chapter 3: Applied Treatment Technology	2.1 Waste water/waste gas management
Chapter 4: BAT Conclusions	2.2 Individual treatment techniques
Chapter 5: Emerging techniques	2.3 Combined treatment techniques
Chapter 6: Concluding remarks	Chapter 3: BAT Conclusions
References	Chapter 4: Emerging techniques
Chapter 7: Annexes	Concluding remarks, references, annexes, glossary
Glossary of terms and abbreviations	

Figure 2: Structure of the revised CWW BREF

1.5 Glossary of terms and abbreviations

The definition of key terms in the Glossary is important to enhance the user friendliness of the CWW BREF. In addition, consistency in the terms used in the whole series of chemical BREFs is essential and this has been recognised by the IEF. The review of the CWW BREF (the first of the chemical BREFs to be reviewed) will set a precedent in this respect (see Section 5.4 of the Comparative analysis of the first series of chemical BREFs).

Conclusions reached by the TWG for the revised CWW BREF:

- definitions of some key terms are missing from the Glossary of the existing CWW BREF
- the TWG should use as much as possible definitions in existing legislation (e.g. 'p.e.' as in the Urban WWT Directive) or in other BREFs (e.g. heavy metals).

The task of the TWG is to identify key technical terms that would be worth defining in the Glossary of the CWW BREF and which could also serve in the Glossary of the other chemical BREFs. The TWG will propose a definition for the key terms identified using the definitions in existing legislation as much as possible.

Information identified or promised to be delivered by the TWG for the revised CWW BREF:

- first series of chemical BREFs
- existing EU legislation (e.g. Directive 2000/76/EC on the incineration of waste, Directive 91/271/EEC on urban waste water treatment).

2 WASTE WATER AND WASTE GAS TREATMENT/MANAGEMENT SYSTEMS

2.1 Environmental management system (EMS)

Conclusions reached by the TWG for the revised CWW BREF:

The task of the TWG is to provide information to improve the section on EMS, e.g. inventories, mass balances, management of changes.

Information identified or promised to be delivered by the TWG:

- industry will provide information concerning the management of changes, particularly for process transfer
- CEFIC will provide information on:
 - management of changes
 - management systems for central treatment plants
- Technip will provide information concerning techniques used for EMS
- relevant information can be found in the OFC BREF.

2.2 Management of a chemical site

Conclusions reached by the TWG for the revised CWW BREF:

The task of the TWG is to provide information on how chemical sites hosting installations covered by several chemical BREFs are managed in order to minimise impact on the environment as a whole (e.g. relationship between the various plant operators and the operator(s) of the central waste water/waste gas treatment plants):

- subcontractors operating waste water/waste gas treatment plants
- multi-operators chemical sites.

Information identified or promised to be delivered by the TWG for the revised CWW BREF:

- France will provide information from example sites with multi-operators, sub-contractors operating waste water/gas treatment plants
- industry (Nicolas Lesage) might provide information concerning sub-contracting of the operation of central waste water treatment plants
- Germany may provide information regarding the management of chemical sites after consulting with the industry.

2.3 Fugitive/diffuse emissions

This item cuts across the whole chemical industry sector. However, it is seldom addressed in the existing CWW BREF. It is therefore proposed that the TWG members provide site-specific information about prevention, capture and abatement of fugitive/diffuse emissions. The vertical chemical BREFs are also a source of information on the subject.

Conclusions reached by the TWG for the revised CWW BREF:

The task of the TWG is to provide information on the prevention and abatement of diffuse/fugitive emissions (especially dust and VOCs), including the minimisation of waste gas volume flows and loads.

Information identified or promised to be delivered by the TWG for the revised CWW BREF:

- CEFIC will provide information on:
 - a new technique for detecting fugitive emissions (especially VOCs)
 - an update of what was already provided for the LVOC BREF
 - a method to determine fugitive emissions used by the CEN and the US EPA
- Germany might provide information on the issue
- Air Liquide will provide the ISO standard method 15848.

2.4 Missing techniques

Conclusions reached by the TWG for the revised CWW BREF:

The task of the TWG is to provide information on:

- the following techniques:
 - green chemistry
 - improved process control
 - process intensification
 - statistical process control
- approaches/measures to minimise emissions from start-ups, shutdowns, abnormal operations.

Information identified or promised to be delivered by the TWG for the revised CWW BREF:

- industry will provide information about green chemistry, in particular on how the 12 principles of green chemistry work and examples of their practical application
- industry will provide information concerning the minimisation of emissions from start-ups, shutdowns, abnormal operations
- the UK will check the possibility of providing information on process intensification
- relevant information can be found in the first series of chemical BREFs, in particular the POL and OFC BREFs.

3 WASTE WATER

3.1 Whole effluent assessment (WEA)

Conclusions reached by the TWG for the revised CWW BREF:

The task of the TWG is to provide information on:

- the latest OSPAR work on whole effluent assessment (WEA)
- the concrete use of WEA or similar techniques in permitting chemical installations/sites.

Information identified or promised to be delivered by the TWG for the revised CWW BREF:

- Sweden will provide information on the latest OSPAR work
- industry (Janssen Pharmaceutica) will provide a case study on the use of WEA
- industry will provide information on the use of WE toxicity assessment
- the UK will check for possible additional information concerning WEA
- ENV NGO might provide information coming from CEN work.

3.2 Missing information or new developments in techniques

Conclusions reached by the TWG for the revised CWW BREF:

The task of the TWG is to:

- update the information on end-of-pipe waste water treatment techniques
- provide information on:
 - the applicability of granulated activated carbon (GAC)
 - advanced oxidation techniques for treating waste waters loaded with toxic compounds
 - to complete the list of substances or air pollutants released by waste water treatments (e.g. N₂O, bioaerosols, sulphur compounds such as methylmercaptan, dimethyl sulphide and dimethyl disulphide). Mercaptans are mentioned on, e.g. p. 13, 20, 125 of the existing CWW BREF, but information can be supplemented if necessary depending on the information sent by the TWG. It is true that mainly H₂S is referred to in the CWW BREF; however, information on the abatement of other sulphur compounds would be useful if it was found to be relevant
 - UV treatment of contaminated waste waters
 - constructed wetlands (e.g. to treat waste waters contaminated by metals)
 - the performance of heavy metals, sulphates and fluoride abatement by precipitation
- provide examples (case studies) that allow the optimum conditions (e.g. pH, mixing, temperature, residence time) for the precipitation of heavy metals to be determined.
- indicate whether electrocoagulation (not mentioned in the CWW BREF) is used or could be used in the chemical industry sector and include information if relevant

-
- specify the non-biodegradable part of waste water by adding a list of typical substances that are not biodegradable
 - specify inhibitory organic or inorganic compounds that disturb the biological process in a biological WWTP and at what concentration these inhibitory effects appear
 - complete information on the recovery/abate solvents from waste waters.

Information identified or promised to be delivered by the TWG for the revised CWW BREF:

- Belgium/Flanders will provide information on end-of-pipe waste water treatment techniques. If information is available from industry, Belgium/Flanders will also provide data on the use of activated carbon
- Austria might provide information on the use of activated carbon
- prior to the kick-off meeting, Spain provided information on an advanced oxidation technique
- data from the OFC BREF can be used, in particular regarding the recovery of solvents and waste acids
- France will provide information on air emissions of central waste water treatment plants, i.e bio-aerosols, sulphur compounds, N₂O, in particular regarding the difficulties in measurements
- the UK will provide information on sulphates precipitation.

4 WASTE GAS

4.1 Wet scrubbers for gas removal and sorbent injection as flue-gas desulphurisation techniques

Conclusions reached by the TWG for the revised CWW BREF:

The task of the TWG is to provide information on the dry injection of sodium bicarbonate and on the comparison between wet scrubbing and dry injection.

Information identified or promised to be delivered by the TWG for the revised CWW BREF:

- Germany might be able to provide information concerning the comparison between wet scrubbing and dry scrubbing systems, if industry would be willing to give information
- industry will provide information on dry scrubbing with sodium bicarbonate (e.g. the temperature range for NEUTREC®, performances of SO₂ and HCl removal and the advantages and disadvantages of various flue-gas treatment processes).

4.2 Control of particulate matter emissions

Information on preventing the emissions and abatement of fine particulate matter is particularly important in the context of the revision of the Directives on air quality which includes limits on ambient concentrations for PM_{2.5}.

Conclusions reached by the TWG for the revised CWW BREF:

The task of the TWG is to provide site-specific information on prevention and abatement of particulate matters (especially PM₁₀ and smaller). The information provided should include sufficient detail so as to enable comparison with other sets of data (see Item 6 on data collection below).

Information identified or promised to be delivered by the TWG for the revised CWW BREF:

- industry (John Zink Keu GmbH) will try to provide information concerning abatement of highly dispersed SiO₂
- Germany will try to provide information concerning the results of fine filtration
- the Netherlands might provide information based on the updating of the Dutch Notes on air emissions reduction techniques.

4.3 Miscellaneous

Conclusions reached by the TWG for the revised CWW BREF:

The task of the TWG is to:

- provide updated information on end-of-pipe techniques to treat waste gases
- cross-reference the Waste Treatments (WT) and Large Combustion Plants (LCP) BREF in the CWW BREF
- include examples where flaring has been avoided or reduced and waste gases have been recovered
- mention the atmosphere explosive (ATEX) Directives 1999/92/EC and 1994/9/EC on the prevention of explosion in the section on choice of waste gas collection systems of the CWW BREF
- provide "real life" examples for the abatement of VOCs from waste gas streams including performance data
- provide information on techniques to abate toxic pollutants (e.g. formaldehyde)
- update or complete information on techniques to abate greenhouse gases such as nitrous oxide (N₂O) and methane (CH₄)
- include missing techniques regarding the reduction of SO_x, H₂S, NO_x and N₂O emissions
- include information on the application of selective catalytic reduction (SCR) – the Netherlands asks if "SCR is well applicable at high sulphur concentrations" could be mentioned in the BREF.

Information identified or promised to be delivered by the TWG for the revised CWW BREF:

- France will provide information on abatement techniques for SO_x, H₂S, NO and N₂O
- Technip will provide information on the performance of SO_x, H₂S and NO_x abatement techniques
- Belgium and the Netherlands will provide information on end-of-pipe waste gas treatment techniques (i.e. Infomil factsheets)
- industry (John Zink Keu GmbH) will provide updated information on SCR and SNCR techniques
- Germany will provide information on "real life" examples for the abatement of VOCs and toxic pollutants
- CEFIC suggests referring to the Large Combustion Plants (LCP) BREF for extensive information on selective catalytic reduction (SCR) and selective non-catalytic reduction (SNCR).

5 OTHER ISSUES

5.1 Combination of techniques

Conclusions reached by the TWG for the revised CWW BREF:

The task of the TWG is to provide information on the combinations of techniques applied in chemical installations to reduce pollution and their associated performance.

Existing information in the existing CWW BREF will be reorganised and clarified as necessary.

Information identified or promised to be delivered by the TWG for the revised CWW BREF:

- France will provide information concerning the combination of techniques for NO_x abatement and more generally for reducing pollutants in combustion gases
- industry will provide information on real cases, as already indicated under Item 2.1.

5.2 Water savings and concentrations of pollutants

Conclusions reached by the TWG for the revised CWW BREF:

- water savings measures can have an influence on the concentration of pollutants and this should be considered when evaluating the cross-media effects of such measures (e.g. performance of a central waste water treatment plant)
- the issue is considered to be part of the overall environmental management system.

The task of the TWG is to provide site-specific information on water savings measures and their effect on the concentration of pollutants in waste waters.

Information identified or promised to be delivered by the TWG for the revised CWW BREF:

- Belgium/Flanders will provide information on cases where concentration is associated with water savings measures
- a text will be proposed by industry to address this issue in the CWW BREF.

5.3 Energy consumption and energy efficiency

Conclusions reached by the TWG for the revised CWW BREF:

- energy efficiency is addressed in the Energy Efficiency (ENE) BREF, it does not need to be duplicated in the CWW BREF
- energy consumption is sector-specific and under the scope of the vertical chemical BREFs
- energy consumption/efficiency of waste water and waste gas treatment plants must be addressed in the CWW BREF.

5.4 Monitoring of emissions

Conclusions reached by the TWG for the revised CWW BREF:

- the CWW BREF will not address the monitoring of receiving water quality. The borderline of CWW should stop at the water discharge point
- Regarding Annex IV on monitoring standards in the existing CWW BREF:
 - the European IPPC Bureau will check the Monitoring (MON) BREF and eventually cross-reference it (the idea being to avoid duplication of information between the MON and CWW BREFs)
 - the list of monitoring standards in Annex IV will be checked against information associated with the implementation of the European Pollutant Release and Transfer (E-PRTR) regulation.

Information identified or promised to be delivered by the TWG for the revised CWW BREF:

- France will provide information on the list of hazardous/toxic substances monitored at French chemical sites
- Germany will provide some "real life" examples (update of information submitted for the OFC BREF).

5.5 Odour

Conclusions reached by the TWG for the revised CWW BREF:

- odour is not considered a major issue for the CWW BREF. Odour is somewhat already covered in the CWW BREF, but not within a specific section
- however, a specific paragraph/section regarding odour should be included in the CWW BREF (because of permitting issues and cross-media effects of techniques)
- the CEN standard for odorous measurements will be cross-referenced in the CWW BREF
- the TWG will examine the vertical chemical BREFs and use any available generic information on odour.

5.6 Waste

Conclusions reached by the TWG for the revised CWW BREF:

- there is already a specific BREF on Waste Treatments (WT) and there is some information in vertical chemical BREFs on this issue. The CWW BREF should not duplicate information
- a paragraph/section on waste management should be included in the CWW BREF.

The task of the TWG is to examine the vertical chemical BREFs and use any available generic information in revising the CWW BREF.

Information identified or promised to be delivered by the TWG for the revised CWW BREF:

- Germany will propose a draft text on this issue. The text will mainly address generic management aspects of waste prevention and treatment and not process-specific issues.

6 DATA COLLECTION

The provision of text and data during the exchange of information is a vital part of reviewing a BREF. The consumption and emissions data in particular are important for identifying the best performers and for identifying a range of performance data that is associated with the use of BAT.

The performance data supplied to the European IPPC Bureau in the past were often aggregated from several installations and were not always accompanied by the necessary supporting operational information. Therefore, these performance data were of limited use in the process of determining BAT and BAT associated emission levels (AELs).

As this has been identified in many of the wishes, the existing CWW BREF contains limited data and information on the current consumption and emission levels and on the performance of techniques to be considered in the determination of BAT, especially on the achievable emission and consumption levels (AELs). Similarly, **the CWW BREF needs major improvements with respect to economics information (i.e. the cost of techniques)**. The recommendations for future work in the existing BREF include the wish to collect more data and information on emission and consumption levels and on the performance of techniques to be considered in the determination of BAT.

6.1 General principles for providing information for the review of the BREF

Conclusions reached by the TWG for the revised CWW BREF:

- provide missing information on: performance (e.g. abatement efficiency), cross-media effects, consumption, economics, reliability, operational data, example plants, driving force for implementation. Under the 'Applicability' of a technique, plant size is a parameter necessary for more systematic assessment
- provide emissions performance in concentrations (e.g. mg/Nm³), load (e.g. kg/year) and, when available, specific load (e.g. kg/t end-product)
- provide site-specific information in non-aggregated form
- accompany emission levels with appropriate averaging period (e.g. yearly average, hourly average) and reference conditions (e.g. O₂ level) and any other relevant information to enable comparison with data from other installations.

6.2 Collecting data on techniques to consider in the determination of BAT

Conclusions reached by the TWG for the revised CWW BREF:

- data on techniques to consider in the determination of BAT should be provided with all the information shown in Annex I (see Section 11 of this report).

6.3 Collecting data on central waste water treatment plants (WWTPs)

A template for the reporting of information on central waste water treatment plants (CWWTPs) is attached as Annex II (see Section 12 of this report).

Conclusions reached by the TWG for the revised CWW BREF:

- provide information from a representative number of CWWTPs under the scope of the CWW BREF, ensuring these include 'best performers'
- there is flexibility in the use of the proposed questionnaire (which can be seen as a checklist): the questionnaires should be completed as much as possible
- use available information to fill in the questionnaires
- information which is confidential should be clearly indicated and only sent to the European IPPC Bureau
- frequency distributions of major parameters (e.g. COD) are considered useful and should be submitted
- some information will be comparable, other information will not
- the analyses of data and the way to reflect these in the CWW BREF will be decided collectively by the TWG at a later stage.

7 SPLIT VIEWS

The existing CWW BREF contains four split views on BAT conclusions. The split views mentioned in the existing BREF concern:

1. The statements on BAT for waste water and waste gas management (p. 275 in the existing CWW BREF)
2. The criterion "relevant non-biodegradable part" of tributary waste water streams (p. 287)
3. BAT associated emission levels (AELs) for heavy metals (p. 294)
4. BAT Associated Emission Levels (AELs) for adsorbable organic halides (AOX, p. 294).

Conclusions reached by the TWG for the revised CWW BREF:

- the new TWG will evaluate information in the existing CWW as well as new data submitted in order to remove the split views on AOX and heavy metals
- the TWG notes that AOX is used in several Member States as a controlling parameter.

The task of the TWG is to provide any additional techno-economic data that could be relevant to resolve the split views.

It can already be noted that industry will provide environmental management systems data for the revision of the CWW BREF which will also include information that could assist in resolving the split view on heavy metals.

8 EMERGING TECHNIQUES

The existing CWW BREF identifies two emerging techniques (in Chapter 5 of the existing BREF). The CWW BREF document was finalised in 2001 and this chapter should be updated taking the developments made over the last few years into consideration. Several EU research projects have been finalised and some emerging techniques may have become techniques to consider in the determination of BAT while others may have been considered as not applicable for the chemical sector.

Conclusions reached by the TWG for the revised CWW BREF:

The task of the TWG is to:

- provide information for updating the status of the emerging techniques mentioned in the existing CWW BREF
- submit information on new emerging techniques.

Information identified or promised to be delivered by the TWG for the revised CWW BREF:

- industry (Astra Zeneca) will provide information concerning new emerging techniques
- the UK will provide information concerning a technique to remove sulphates
- Technip will provide information on a number of tools for the management of changes
- France will provide information on several techniques:
 - Monashell Bio-Filtration Technology (H₂S, mercaptans)
 - Photocatalysis (odours, VOC)
 - CIRCOX/vertical aerobic biological reactor (COD, nitrogeous compounds)
 - ceramic filters (NO_x).

9 PROCESS TO REVIEW THE CWW BREF

A proposal for the specific planning to review the CWW BREF was given by the European IPPC Bureau and discussed at the meeting.

The TWG agreed that the **deadline for submitting information** should be **9 January 2009**.

The TWG also agreed the following general time schedule for the review of the CWW BREF (milestones in grey have been completed).

	CWW BREF review milestones	Expected dates
1	Reactivation of the TWG	EIPPCB e-mail dated 28/11/2007
2	Call for wishes	EIPPCB e-mail dated 25/01/2008: the deadline for sending wishes to the EIPPCB was set at 31/03/2008. The compiled list of TWG wishes was sent by email to the TWG on 16/04/2008
3	Kick-off meeting	16/06/2008 – 18/06/2008
4	Collection of information	Deadline to submit new information: 9 January 2009
5	Consultation/meeting for discussing the new information	If deemed necessary
6	Draft of the revised BREF (without the BAT chapter)	<i>June – September 2009</i>
7	TWG comments on the draft (without the BAT chapter)	<i>October – November 2009</i>
8	Draft of the BAT chapter and associated chapters on 'Techniques to consider in the determination of BAT'	<i>December 2009 – January 2010</i>
9	TWG comments on the BAT chapter and associated chapters on 'Techniques to consider in the determination of BAT'	<i>February – March 2010</i>
10	Final TWG meeting (mainly to discuss the BAT chapter)	<i>Summer 2010</i>
11	Final draft	<i>Autumn 2010</i>
12	Presentation of the revised BREF at an IEF meeting	<i>Winter 2010 at the earliest</i>

Table 1: Milestones for the review of the CWW BREF

Dates in italics represent dates where the milestones are expected to happen. These are indicative periods and strongly depend on the amount of information provided and the difficulty of the topics.

10 INFORMATION EXCHANGE

An effective information exchange is dependent on the active involvement of all TWG members. The TWG is expected to collaborate fully and to use objective scientific communication to support the views expressed. Information submissions may take the form of quantitative data or qualitative descriptions, but must be made by **9 January 2009**. Earlier submissions are obviously welcome. **There is no guarantee that late information will be taken into account.**

The e-mail and the European IPPC Bureau information exchange forum (within the BAT Information System, BATIS) both play an important role in the information exchange. The exchange of information necessarily involves public disclosure, but there is a provision for accepting confidential submissions. In this case, this request should be clearly communicated to the European IPPC Bureau.

The TWG will also have access to a workspace (BATIS forum for CWW) for exchanging information. The CWW forum in BATIS is only accessible to members of the CWW TWG and to European IPPC Bureau staff. An invitation to join BATIS has been sent by e-mail to all TWG Members. Should you request any assistance in the use of BATIS, please do not hesitate to contact the European IPPC Bureau secretariat (email: jrc-ipts-eippcb@ec.europa.eu; tel.: +34 954 488 284; fax: +34 954 488 426).

Site visits to installations constitute a good method for gathering and validating information. Some TWG members have already offered their help to organise site visits for the BREF Author. Visits will be prepared in advance so that the topics to be discussed can be selected and studied.

11 ANNEX I: STANDARD STRUCTURE FOR DESCRIBING THE 'TECHNIQUES TO CONSIDER IN THE DETERMINATION OF BAT'

When providing information on 'Techniques to consider in the determination of BAT', the use of a standard structure is required in order to enable comparisons of techniques and so that an objective assessment against the definition of BAT given in the IPPC Directive can be made. This standard structure is stipulated in the BREF Outline and Guide and is as shown in Section 11.1. It is necessary to use this standard structure for the provision of information for specific techniques.

11.1 Type of information needed to fill the sections dealing with 'Techniques to consider in the determination of BAT' and to derive useful BAT conclusions

In order to determine BAT, all techniques to be considered in the BAT decision making process will be presented in the BREF according to a standard structure, shown in the first two columns of the following table. The third column gives more details on the specific data which are needed from the TWG members in order to draft 'Techniques to consider in the determination of BAT' and to derive useful BAT conclusions from them:

Name of the type of information	Type of information to be included in the BREF	Important information to collect and to report ¹
Description	Technical description of the technique (including drawings, schematics if necessary)	The description can include both prevention and control measures (in-process and end-of-pipe)
Achieved environmental benefits	The main environmental impacts (including energy, water, raw material savings, as well as production yield increases), addressed by the technique	
Cross-media effects	Any side effects and disadvantages to other environmental media (e.g. air, water, land) caused by implementation. Environmental effects of the technique in comparison with others	The Reference Document on Economics and Cross-media Effects (ECM) is a document that should be taken into account with regard to cross-media aspects as far as there are significant cross-media effects. This document is available from the European IPPC Bureau website at http://eippcb.jrc.es/pages/FActivities.htm
Operational data	Data on consumption and emission levels from operational plants using the technique (including reference conditions – e.g. O ₂ level – and monitoring methods used). Any other information on how to operate, maintain and control the technique	<p><u>Emissions data</u> (see also Sections 6.1 and 6.2):</p> <ul style="list-style-type: none"> • both the concentration and (specific) load of pollutant(s) (if available) or the data needed to derive this information. For specific load data, the product referred to should be clearly defined • the quantity of pollutant before and after the abatement system in order to determine the abatement efficiency • the Reference Document on General Principles of Monitoring (MON) is a document that should be taken into account with respect to the expression of monitoring results and how to deal with uncertainties, emission factors, direct measurements and monitoring requirements <p><u>Consumption data:</u></p> <ul style="list-style-type: none"> • the type and amount of fuel, energy (heat, electricity), water and raw materials/chemicals consumed/used by the technique <p><u>Waste:</u></p> <ul style="list-style-type: none"> • the type and quantities of waste generated and treatment/disposal methods and/or techniques to prevent waste <p><u>Others:</u></p> <ul style="list-style-type: none"> • sensitivity and durability of the technique

¹ based on the main gaps identified during the elaboration of the first series of BREFs

Name of the type of information	Type of information to be included in the BREF	Important information to collect and to report ¹
		<ul style="list-style-type: none"> operation/control/maintenance issues
Applicability	Indication of the type of plants in which the technique may be applied, considering, e.g. plant age (new or existing), plant size (large or small), techniques already installed and type of product	<p>Examples:</p> <ul style="list-style-type: none"> information on retrofitting of parts of the installation
Economics	Information on costs (both investment and operational) and possible savings, including details on how these costs have been calculated	<p>Mainly:</p> <ul style="list-style-type: none"> capital/investment, operating and maintenance costs including details on how these costs/savings have been calculated/estimated possible savings (including payback time), including details on how these costs/savings have been calculated/estimated cost data will preferably be given in euros (EUR). If a conversion is made from another currency, the data in the original currency and the year when the data were collected will be indicated. This is important as conversion rates vary over time price/cost of equipment or service will be accompanied with the year it was purchased information on the market for the sector to put costs of techniques into context <p>The Reference Document on Economics and Cross-media Effects (ECM) and the Reference Document on the General Principles of Monitoring (MON) should be taken into account with regard to economic aspects and monitoring costs, respectively. Both documents are available from the European IPPC Bureau website at http://eippcb.jrc.es/pages/FActivities.htm</p>
Driving force for implementation	Local conditions or requirements which lead to or may stimulate implementation. Information on reasons other than environmental ones for implementation (e.g. increase in productivity, safety)	<p>Examples:</p> <ul style="list-style-type: none"> information on type/quality of receiving waters (e.g. temperature, salinity) information on environmental quality standards information on the increase of production or productivity
Example plants	Reference to plants in which the technique is applied and from which information has been collected	
Reference literature	Literature that was used in writing the section and that contains more details	

**12 ANNEX II: TEMPLATE FOR THE PROVISION OF
INFORMATION ON CENTRAL WASTE WATER TREATMENT
PLANTS (WWTP)**



EUROPEAN COMMISSION
DIRECTORATE-GENERAL JRC
JOINT RESEARCH CENTRE
Institute for Prospective Technological Studies
Competitiveness and Sustainability Unit
European IPPC Bureau

QUESTIONNAIRE ON **CENTRAL WASTE WATER TREATMENT PLANTS (WWTP)** IN THE CHEMICAL SECTOR

1 INFORMATION ABOUT THIS QUESTIONNAIRE

1.1 Purpose of the questionnaire

Within the framework of the implementation of the IPPC Directive and the review of the European reference document on the Best Available Techniques (BAT) in **Common Waste Water and Waste Gas Treatment/Management Systems in the Chemical Sector (CWW)**, the purpose of this questionnaire is to obtain site-specific information regarding the environmental performance of central waste water treatment plants (WWTP) treating waste waters from various chemical installations. Figure A on the following page shows how the sections of this questionnaire relate to the proposed extended scope of the CWW BREF.

1.2 If any information requested are confidential please specify this

The information submitted will be used for the purpose of the review of the CWW BREF. If the information submitted is of a confidential nature, it will only be dealt with by European IPPC Bureau personnel.

1.3 What if you do not have all the information requested

You are asked to submit the information that you have to hand. Partial information is also useful. Please do not hesitate to submit any extra information that you find relevant together with this questionnaire and in the form that you consider relevant (an electronic form is preferred).

1.4 Year of reference

Please indicate the year of reference for the data provided in this questionnaire.

Year:

1.5 Person completing the questionnaire

Name:

Job Title:

e-mail:

Tel.:

This information will only be used if further clarification is needed

In case of doubt in completing this questionnaire, please do not hesitate to contact:

Serge Roudier at 34+ 954 488 308

WHEN COMPLETE, PLEASE SEND THIS QUESTIONNAIRE TO

serge.roudier@ec.europa.eu

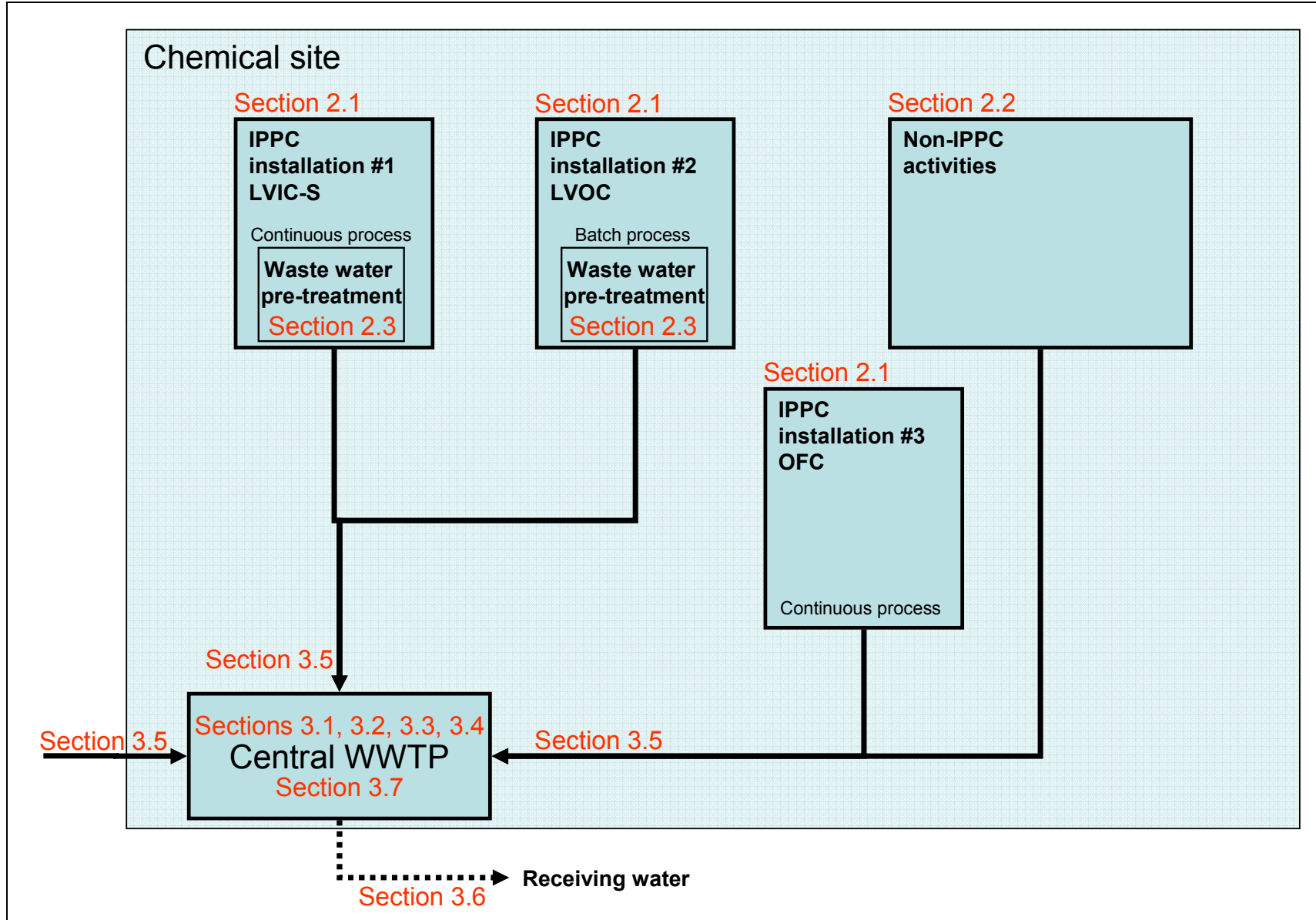

Figure A: Relationship between the sections of this questionnaire and the proposed extended scope of the CWW BREF

2 INFORMATION ON THE CHEMICAL SITE

A general scheme showing the chemical site and the various production units could usefully be provided together with the filled-in questionnaire.

2.1 IPPC chemical installations at the site

2.1.1 Production of inorganic substances

Are there installations covered by the **Large Volume Inorganic Chemicals – Solids and others (LVIC-S)** BREF?

No

Yes If yes, indicate the production process and number of installations:

Soda ash Remarks:

Titanium dioxide..... Remarks:

Carbon black..... Remarks:

Synthetic amorphous silica Remarks:

Inorganic phosphates..... Remarks:

Any other LVIC-S substance: Remarks:

Not sure If you are not sure, please indicate the type of production:

Are there installations covered by the **Large Volume Inorganic Chemicals – Ammonia, Acids and Fertilisers (LVIC-AAF)** BREF?

No

Yes If yes, indicate the production process and number of installations:

Ammonia Remarks:

Nitric acid..... Remarks:

Sulphuric acid..... Remarks:

Phosphoric acid..... Remarks:

Hydrofluoric acid..... Remarks:

NPK and CN..... Remarks:

Urea and UAN..... Remarks:

AN and CAN..... Remarks:

Superphosphates Remarks:

Any other LVIC-AAF substance: Remarks:

Not sure If you are not sure, please indicate the type of production:

Are there installations covered by the **Chlor-Alkali (CAK)** BREF?

No

Yes If yes, indicate the production process and number of installations:

Mercury cell Remarks:

Membrane cell Remarks:

Diaphragm Remarks:

Not sure If you are not sure, please indicate the type of production:

**Data collection for the review of the BREF on Common Waste Water and Waste Gas
Treatment/Management Systems in the Chemical Sector (CWW)**

Are there installations covered by the **Speciality Inorganic Chemicals (SIC)** BREF?

No

Yes If yes, indicate the production process and number of installations:

Inorganic pigments Remarks:

Phosphorus compounds... Remarks:

Silicones Remarks:

SIC explosives Remarks:

Cyanides Remarks:

Other SIC Remarks:

Any other SIC substance: Remarks:

Not sure If you are not sure, please indicate the type of production:

2.1.2 Production of organic substances and polymers

Are there installations covered by the **Large Volume Organic Chemicals (LVOC)** BREF?

No

Yes If yes, indicate the production process and number of installations:

Lower olefins Remarks:

Aromatics Remarks:

Ethylene oxides and

Ethylene glycols Remarks:

Formaldehyde Remarks:

Acrylonitrile Remarks:

Ethylene dichloride and

vinyl chloride monomer .. Remarks:

Toluene diisocyanate Remarks:

Any other LVOC substance: Remarks:

Not sure If you are not sure, please indicate the type of production:

Are there installations covered by the **Organic Fine Chemicals (OFC)** BREF?

No

Yes If yes, indicate the production process and number of installations:

Pharmaceuticals Remarks:

Organic intermediates..... Remarks:

Specialised surfactants.... Remarks:

Flavours, fragrances,

pheromones Remarks:

Optical brighteners Remarks:

Flame retardants Remarks:

Dyes and/or pigments Remarks:

Explosives Remarks:

Any other OFC substance: Remarks:

Not sure If you are not sure, please indicate the type of production:

Are there installations covered by the **Polymers (POL)** BREF?

No

Yes If yes, indicate the production process and number of installations:

Polyolefins Remarks:

Polystyrene Remarks:

Polyvinyl chloride Remarks:

Emulsion polymerised

styrene Remarks:

Butadiene rubber Remarks:

**Data collection for the review of the BREF on Common Waste Water and Waste Gas
Treatment/Management Systems in the Chemical Sector (CWW)**

Solution polymerised rubber containing butadiene	<input type="checkbox"/>	Remarks:
Polyamides	<input type="checkbox"/>	Remarks:
Polyethylene terephthalate fibres	<input type="checkbox"/>	Remarks:
Viscose fibres	<input type="checkbox"/>	Remarks:
Any other POL substance:		Remarks:

Not sure If you are not sure, please indicate the type of production:

2.1.3 Other IPPC installations

Are there other IPPC installations at the chemical site?

No

Yes If yes, please indicate which installations and whether the waste waters generated are treated in the central waste water treatment plant (WWTP):

2.2 Non-IPPC installations or activities

Are there non-IPPC activities carried out at the chemical site (e.g. production of industrial gases)?

No

Yes If yes, please indicate which installations and whether the waste waters generated are treated in the central waste water treatment plant (WWTP):

3.4 Relationship between installations generating waste waters and the central WWTP

Please indicate the management system put in place between the operators of the individual installations generating waste waters (as indicated in Section 2.1 and 2.2 above) and the operator of the central WWTP so as to ensure the optimum results with regard to the environment (i.e. minimisation of emissions to water and air, minimisation of the consumption of energy and materials). Please indicate if criteria are defined (and which ones) for deciding whether waste water streams can be discharged to the central WWTP (e.g. biodegradability/bioelimination, heavy metals content):

3.6.3 Energy generated

Please indicate in the table below whether energy is produced, in what form (e.g. electricity, steam) and how much. If steam is produced, the temperature and pressure of the steam should also be given. **An example is shown in green.**

Energy produced	Quantity	Unit e.g. MWh/year	Remarks
Electricity	1000	MWh/year	

Is energy sold? No
 Yes If yes, in what form?
 Electricity
 Steam

Please indicate whether there is recovered energy (in what part of the WWTP, under which form and how much?):

3.6.4 Whole effluent assessment/biotests/biomonitoring

Is whole effluent assessment (WEA)/biotests/biomonitoring used?

No
 Yes If yes, please provide below a summary of the test methods employed as well as how the results are used (e.g. for hazards assessment, monitoring or compliance):

3.6.5 Performance of the central WWTP

Parameter monitored	Influent					Effluent					Elimination rate (1 - percentage of the pollutant in the influent left in the effluent)
	Concentration		Load		Averaging time period e.g.: yearly average of 24 hours composite samples	Concentration		Load		Averaging time period e.g.: yearly average of 24 hours composite samples	
	Value* e.g.: Min [10] 20 Max [50]	Unit e.g. mg/l	Value* e.g.: Min [10] 20 Max [50]	Unit e.g. kg/yr		Value* e.g.: Min [10] 20 Max [50]	Unit e.g. mg/l	Value* e.g.: Min [10] 20 Max [50]	Unit e.g. kg/yr		
pH											
TOC (Total Organic Carbon)											
BOD ₅ (Biological Oxygen Demand 5 days)											
BOD ₇ (Biological Oxygen Demand 7 days)											
COD (Chemical Oxygen Demand)											
TSS (Total Suspended Solids, dried 105 °C)											
AOX (Adsorbable Organic Halogens)											
Cd total											
Cr total											
Cr (VI)											
Cu total											
Hg total											
Ni total											
Pb total											
Zn total											
Total Nitrogen (as N)											
Ammonia (NH ₄ - N)											
Nitrite (NO ₂ - N)											
Nitrate (NO ₃ - N)											
P total											
PO ₄ - P											
Phenols											
Chlorides											
Sulphates											
CN (free)											
Fish or fish egg toxicity (dilution factor)	X										X
Daphnia toxicity (dilution factor)											
Algae toxicity (dilution factor)											
Luminescence bacteria toxicity (dil. factor)											

* The values in brackets are the minimums and maximums found in the period (e.g. within a year). The value between the ones in brackets (i.e. 20 in the example provided) is determined using the averaging time period indicated in the column to the right. If frequency distributions are available for the major parameters monitored they should be submitted

3.6.6 Monitoring regime

Indicate the type of monitoring carried out at the level of unit operations/processes or equipment as indicated in Section 3.2 and 3.3 above (add in the blank columns the operations/processes or equipment): C = continuous measurement; S = samples. In the case of samples, indicate the method/standard used as well as the frequency of sampling. *Examples are shown in green.*

Parameter monitored	Influent	Effluent	Neutralisation	Outlet buffer to biology						
Waste water flow										
pH			C	C						
Temperature										
Bacteria toxicity										
Dissolved oxygen										
TOC (Total Organic Carbon)				C						
BOD ₅ (Biological Oxygen Demand 5 days)				S Method X 4 x year						
BOD ₇ (Biological Oxygen Demand 7 days)										
COD (Chemical Oxygen Demand 2 hours)										
TSS (Total Suspended Solids, dried 105°C)										
AOX (Adsorbable Organic Halogens)										
As total										
B total										
Cd total										
Cr total										
Cr (VI)										
Cu total										
Hg										
Ni total										
Pb total										
Zn total										
Total Nitrogen (as N)				C						
Ammonia (NH ₄ - N)										
Nitrite (NO ₂ - N)										
Nitrate (NO ₃ - N)										
P total				C						
PO ₄ - P										
Phenols										
Chlorides										
Sulphates										
CN (free)										

